

TDYN: THE ULTIMATE SIMULATION TECHNOLOGY

Tdyn features a comprehensive simulation suite that provides solution to nearly any engineering calculation need. The product offers a unique solution for structural, flow, heat transfer, fluid-structure interaction, multi-physics and sea-keeping problems in a single integrated package. Tdyn is conceived to merge with your current engineering processes, increasing your productivity and helping you to optimize your designs. Tdyn introduces a variety of tools to interact with your analyses, allowing having a perfect control over the design process.

Tdyn integrates three analysis packages; **Tdyn CFD+HT**, **RamSeries** and **SeaFEM**, offering 12 simulation modules and giving answer to almost any calculation need. The various Tdyn packages available are fully integrated in a unique Graphic User Interface (GUI) for geometry and data definition, mesh generation and post-processing of the analysis results. Tdyn's GUI uses a versatile tree-like interface for data managing, allowing an easy control of the whole process.

Tdyn's MODULES CHART

Tdyn CFD+HT modules
Ransol: Fluid Dynamics solver
Heatrans: Heat transfer analysis
Advect: Transport of mass/species
Ursolver: User-defined PDE solver
Alemesh: Mesh updating tools
RamSeries modules
Basic: linear static analysis
Dynsol: dynamic (modal and direct) analysis
Composite: laminated composite calculation tools
Non-linear: non-linear, impact and other advanced tools
Coupling: implicit fluid-structure interaction solver
SeaFEM modules
Basic: time domain multi-body linear diffraction-radiation solver
Advanced: second order diffraction-radiation solver and hydroelasticity analysis

To assist in the data definition process, Tdyn's GUI allows to easily select and configure the type of analysis that is going to be carried out (structural analysis, CFD, multi-physics, fluid-structure interaction, etc), minimizing the time required to insert the analysis data.

Tdyn meshing technology includes a suite of tools to create in an automated way, high-quality unstructured, structured and semi-structured meshes, including boundary layer meshes.

The variety of tools provided by Tdyn allows to have a perfect control over the process and to verify its quality. In particular, Tdyn offers a wealth of intuitive visualization capabilities, delivering a flexible way to extract features of the physics of the model, and driving faster decisions with confidence.

TDYN CFD+HT PACKAGE

Tdyn CFD+HT is much more than just a Computational Fluid Dynamics (CFD) solver. It constitutes an entire engineering solution for solving problems involving flow (fluids and porous media), heat transfer (fluids and solids) and multi-physics. At the heart of Tdyn CFD+HT is its leading finite calculus (FIC-FEM) solver technology, quickly offering reliable, robust and accurate solutions. Tdyn CFD+HT flexible analysis solution has been applied to the simulation of aerodynamics of buildings, water flow about ship hulls, glass bottle making processes, cooling of electronic devices, flow in pumps and fans, studies of HVAC systems, and much more.

A more detailed explanation of the capabilities of every Tdyn CFD+HT module is given next.

RANSOL MODULE

Tdyn CFD+HT's Ransol module features the latest technology for solving real fluid flows in 3D (transient or steady), including turbulence effects. The fluid models available allow solving from fully compressible to incompressible fluid flow problems and porous media flows (Stokes problem in solid materials).

Physical properties and other problem data used within this module can be defined in terms of any other variable of the problem (i.e. temperature, pressure, etc.). This way, it is possible to analyze fluids with variable viscosity or define external floatability forces acting on the fluid. Ransol module also allows the definition of non-linear Darcy's law effects.

Tdyn CFD+HT allows choosing between 14 different predefined turbulence models, including RANS, ILES (Implicit Large Eddy Simulation) and DES (Detached Eddy Simulation) types. It also permits to define new models based on analytical expressions or systems of PDEs (see Ursolver module).

Ransol module includes tools for defining space varying,

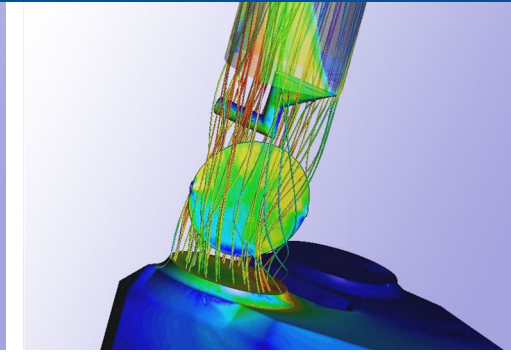
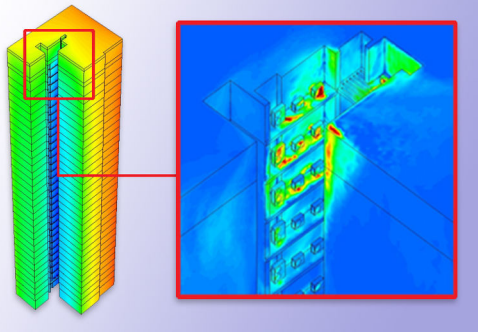

transient and advanced boundary conditions. This way, profiles of velocity and pressure can be specified on openings and walls.

HEATRANS MODULE

Heatrans module is able to solve complex forced, natural, and mixed convection heat transfer problems in fluids and heat conduction problems in solids.

This module also includes conjugate heat transfer (CHT) technology where the calculation of thermal conduction through solid materials is coupled with the calculation of the temperature in the working fluids.

TDYN CFD+HT'S CAPABILITIES CHART	
3D, 2D and axi-symmetry FIC-FEM Reynolds eqs. solvers	✓
Fluid models: fully incompressible, slightly compressible, barotropic, incompressible ideal gas, ideal gas	✓
Advanced structured and unstructured meshers, including boundary layer mesh generation	✓
Different RANS, ILES (Implicit Large Eddy Simulation) and DES (Detached Eddy Simulation) turbulence models	✓
Convection-conduction (fluids) and conduction (solids) heat transfer solver	✓
Coupled fluid-solid heat transfer (conjugate heat transfer technology)	✓
Free surface (ODDLS and transpiration) solvers	✓
Space varying, transient and advanced boundary conditions	✓
Arbitrary Lagrangian-Eulerian (ALE) solver for moving meshes	✓
Mesh updating: prescribed / free bodies movement, explicit and combinations of these strategies	✓
Generic user-defined PDE solver	✓
Advection/diffusion of mass/species in fluids and solids	✓
Scripting programming interface based on the scripting language Tcl-Tk	✓
Cutting-edge GPU accelerated and parallel CPU-SMP iterative solvers	✓

All the problem data can be defined in terms of any other variable of the problem. This way it is possible to analyze solids with variable heat capacity, define profiles of heat fluxes in walls or even simulate problems including phase change.

Furthermore, Heatrans module features advanced surface-surface contact and surface-surface distance boundaries, for definition of linear and non-linear thermal resistances and advanced boundary conditions.

ADVECT MODULE

This module allows solving problems concerning the advection/diffusion of mass/species in fluids, including reactive effects. It is also able to solve species diffusion problems in solids (Fick's law).

The Advect module allows defining and tracking the evolution of a number of new species. The physical properties and behavior of the fluid flow are further defined in terms of the species concentration variable.

Tdyn CFD+HT incorporates FIC-FEM algorithms to increase stability and accuracy of advection/diffusion problems.

URSOLVER MODULE

Ursolver module offers the ability to solve generic user-defined PDE problems in fluids and solids. This module allows defining a number of new variables (ϕ problems) and to specify and solve the differential equations that govern the actual behavior of the variables. New user-defined problems can be coupled among them or with any other variable used in Tdyn CFD+HT (i.e. velocity, pressure, temperature ...).

The Ursolver module features a powerful Tcl-based scripting interface enabling integration into design processes, faster completion of repetitive tasks and further extension of Tdyn capabilities. Tdyn scripting interface provides an interpreter for the standard Tcl scripting language, enabling users to enhance simulations without recourse to external compiled subroutines. Furthermore, Tdyn Tcl interface provides access to advanced features, including operations on internal structures and execution / communication with external programs.

Tdyn scripting interface also offers a library for vector and matrix operations, including mesh interpolation tools which makes easy to connect Tdyn with other solvers.

ALEMESH MODULE

When the analysis require geometry updating, Alemesh offers several mesh updating strategies, including prescribed / free bodies movement with automatic mesh updating, explicit 3D mesh movement via user functions and combinations of both

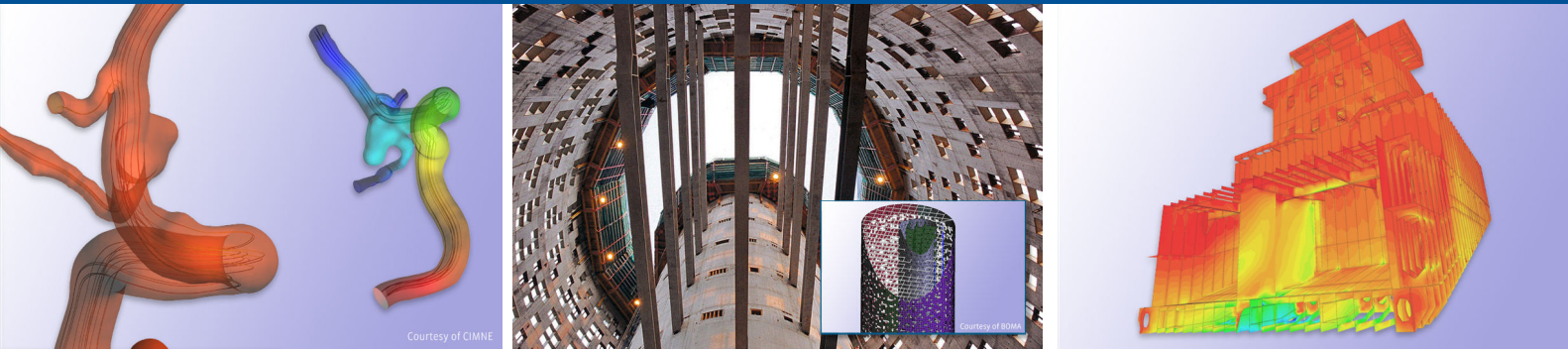

strategies. These algorithms cover almost every conceivable mesh movement need.

Furthermore, Alesh module features advanced Arbitrary Lagrangian-Eulerian (ALE) algorithms, offering faster and accurate results in problems that involve moving meshes, including fluid structure interaction (FSI) analyses.

FSURF MODULE

Fsurf module features the leading overlapping domain decomposition level set technique, developed by Compass IS for free surface simulation. This methodology is based on the application of domain decomposition techniques and allows increasing the accuracy of the free surface capturing, as well as precisely solving governing equations in the interface between two fluids, taking into account surface tension effects. The greater accuracy in the solution of the interface between the fluids allows the use of non-structured meshes. Fsurf module includes robust mass conservation techniques and optimized surface tracking algorithms, increasing the accuracy in capturing sharp interfaces between two fluids and efficiently solving problems with large free surface deformation. Furthermore, Fsurf module features a state-of-the-art algorithm for towing analysis, based on the transpiration technique, largely improving the resolution of the free surface deformation, even for coarse meshes.

RAMSERIES PACKAGE

RamSeries is a complete finite element (FEM) environment for structural analysis. It is fully integrated in the Tdyn suite, and provides the ability to simulate every structural aspect of a product thanks to its full range of capabilities, including linear statics, modal analysis, linear and non-linear transient simulations, impact, coupled fluid-structure analyses, thermo-mechanical studies, fatigue assessment and much more. RamSeries is the simulation solution to rapidly solve complex structural problems with ease.

RamSeries features a full range of 3D element models, including beams, cables, shells, membranes and solid elements, as well as a full support for nonlinear analysis, including nonlinear and linear material laws, and large displacement models. Furthermore, RamSeries features the latest technology for solving structural dynamics analyses, including contact-impact algorithms, which permits the analysis of most practical

problems in engineering.

RAMSERIES' CAPABILITIES CHART

Fully integrated graphic user interface (GUI)	✓
Line models: 3D beams and cables	✓
Shell element models: 4-8 nodes quads, 6 nodes triangles, DKT, 3 nodes triangles with drilling rotation, and stiffened shells	✓
3D solid element models: 4-10 nodes tetras and 8-20 nodes hexas	✓
Advanced structured and unstructured meshes	✓
Linear statics calculation	✓
Dynamic, modal and direct time integration, analysis	✓
Element to element contact-impact algorithm, including contact elements and automatic beam-shell contacts	✓
Nonlinear tools: large displacements, plasticity and NL constraints	✓
P-Delta buckling-analysis method	✓
Composite laminated shells and beams	✓
Fatigue assessment (DNV-RP-C203, API RP 2A-WSD)	✓
One-way and two-way implicit fluid-structure interaction solvers (Ransol module required)	✓
One-way and two-way implicit seakeeping-structure coupled solvers (SeaFEM package required)	✓
Thermo-mechanical solver (Heatrans module required)	✓
Tools for automatic generation of parametric models (based on XML technology)	✓
Cutting-edge parallel CPU-SMP direct/iterative sparse-matrix solvers	✓
Scripting programming interface based on the scripting language Tcl-Tk	✓

RamSeries offers advanced utilities to analyze structures made of laminated composites, and provides an intuitive interface to define materials, laminate sequences and ply direction, based on geometric lines orientations or local or global frames of reference. LaRC04 failure criteria, including six failure modes, and Tsai-Wu criteria for obtaining the security factor (global, and per ply) are available. Furthermore, RamSeries includes specific tools for naval architecture and offshore engineering applications, including stiffened shells, static and dynamic

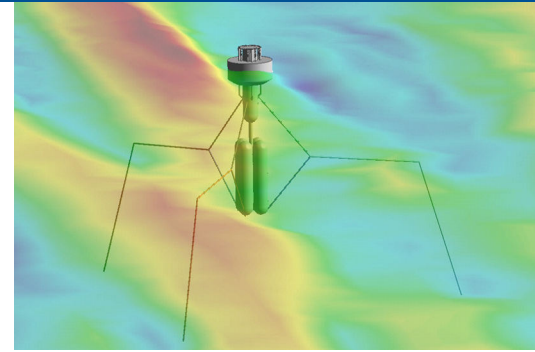
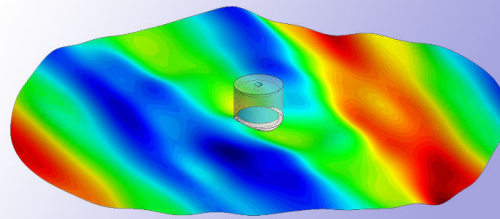
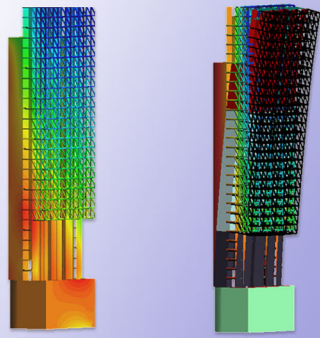

wave loads, and fatigue assessment tools. RamSeries offers seamless communication with Tdyn's Heatrans, Ransol and SeaFEM modules for thermo-mechanical and coupled fluid-structure analyses.

RamSeries package is organized in different modules: Basic for linear static analysis; Dynsol for transient (modal and direct) studies as well as seismic analysis; Composite for laminated composite calculations; Non-linear for non-linear and impact-contact analysis as well as including different tools for marine applications and fatigue assessment; and Coupling, featuring solvers for implicit fluid-structure interaction and thermo-mechanical analysis.

SEAFEM PACKAGE

SeaFEM is a leading-edge platform for seakeeping analysis, offering a suite of tools for the computational analysis of the effect of waves, wind and currents on naval and offshore structures, as well as for maneuvering studies. SeaFEM has been developed for the most realistic seakeeping simulations of 3D multi-body radiation and diffraction problems.

SEAFEM'S CAPABILITIES CHART

3D Time domain FEM multi-body wave diffraction and radiation	✓
Forward speed with stream-line and SUPG integration	✓
Seakeeping, towing, maneuvering, extinction tests and RAOs	✓
Nonlinear hydrodynamics, drift effects and transom stern flows	✓
Linear and second order radiation-diffraction solver	✓
Regular and irregular (spectral) waves, including user defined spectrum	✓
Bathymetry: infinite depth, constant depth and irregular seabed	✓
External forces and connections between bodies	✓
Build-in multi-segment mooring models including dynamic FEM cable, spring and quasi-static catenary	✓
Cutting-edge direct sparse and deflated CG solvers. CUDA GPU acceleration available	✓
Advanced Tcl programming interface	✓

SeaFEM is based on the solution of potential flow equations in the time domain, using the finite element method on unstructured meshes. SeaFEM features unique capabilities for global performance analysis of moored and/or connected systems subject to random sea states. SeaFEM applications include ships, spar, semi-submersible and TLP platforms, FPSOs, marine wind turbines and ocean energy harnessing devices.

SeaFEM has been conceived to simulate seakeeping capabilities of ships and offshore structures, as well as to calculate the hydrodynamic loads due to waves, currents, and translational velocities acting simultaneously. Moreover, the solver has been equipped with the capability of introducing any external loads acting over the structure under study. Furthermore, effects of mooring lines can be simulated by using built-in models.

SeaFEM is fully integrated in the Tdyn suite, facilitating the communication with the Tdyn's structural analysis package, RamSeries, thus allowing to perform the most advanced hydroelasticity studies.

INFORMATION

For further information, please visit:

<http://www.compassis.com/tdyn>

A free version of Tdyn, limited in the number of mesh nodes, can be downloaded from the Tdyn website. A one month password for activating all the capabilities for demonstration purposes can be obtained at the same site.

System requirements

Windows NT / XP / XP64 / Vista / Vista 64 / 7 / 7 64-bits / 8 / 8 64-bits or Linux 32/64

Please ask us for Tdyn versions in other platforms

Minimum requirements: 2.0 GB RAM (4 GB for 64 bits editions) and 500 MB of free hard disk space.

For information about conditions and prices of commercial licences, please contact info@compassis.com